

## Care Solutions · Nylon Care 400

Nylon Care 400 Lift-up support rail,  
with remote control

Article number: 4447365067

### Product image



### Technical specifications

Product group	2000
Product	Lift-up support rail, with remote control
Length	850 mm
Diameter	34 mm
Material	polyamide
Surface	high-gloss with antibacterial protection and textured surface for non-slip grip
Colour	available in colours Dark grey (018), White (019) and Manhattan (067)
Version	left
Loading	max. 125 kgs

### Technical drawing

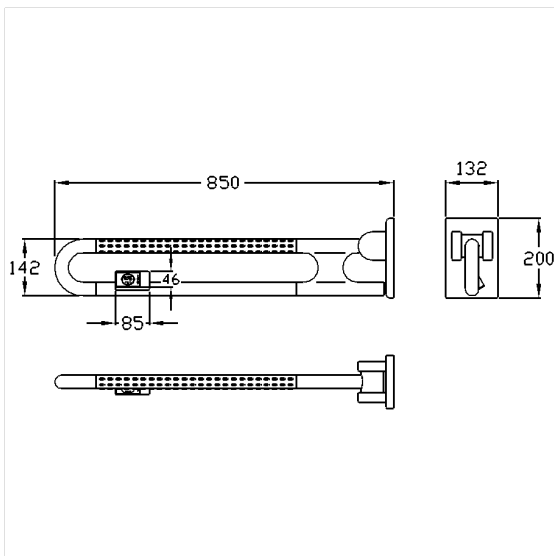

### Product description

- Nylon Care - a well-trying and proven product family with a wide range of variants, three product series suiting many different requirements
- with adjustable brake
- with durable maintenance-free, friction bearings
- with non-corrosive steel core throughout
- spring-loaded mechanism, smooth-running folding
- 868,4 MHz wireless remote control for WC flush, casing measurements: 85 x 46 x 16mm, compatible for Geberit: 115.867.00.1, 115.869.00.1, 115.897.00.1, 115.898.00.1, 115.867.SN, 115.869.SN, Grohe: 38759SD0, Sanit: 05.042.00..0000, 05.014.00..0000, 05.015.00..0000, Tece: 9.240.354, 9.240.355, Viega: 696177
- with steel reinforced mounting plate for three-point fixing and Nylon cover
- concealed screw fixing
- In case of lightweight partition walls a backfill made of min. 20mm hardwood is needed
- certified by TÜV PRODUCT SERVICE
- produced in accordance with Regulation (EU) 2017/745 on medical devices
- CE-certified
- meets the requirements of German standard DIN 18040 and Austrian standard ÖNORM B 1600
- Fixing set has to be determined according to conditions on site, is to be ordered separately



Antibac



018 019 067