

Verso Care Shower handrail,  
with movable shower handrail

Article number: 3500352018

### Product image



### Technical specifications

Product group	3800
Product	Shower handrail, with movable shower handrail
Axle dimension a1	750 mm
Axle dimension a2	750 mm
Axle dimension a3	1100 mm
Fixing type	single-point mounting
Fixing points	5 Piece
Diameter	34 mm
Material	polyamide
Surface	high gloss
Colour	available in nylon colours
Version	left
Loading	max. 175 kgs

### Technical drawing

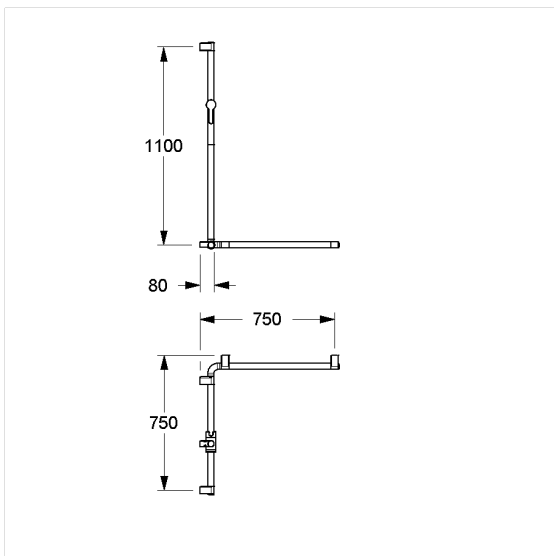

### Product description

- Nylon Care - a well-trying and proven product family with a wide range of variants, three product series suiting many different requirements
- with non-corrosive steel core throughout
- Shower head holder with easy adjustment to any height and angle, self-adjusting clamp maintenance-free
- side-mounted operating lever for one-handed operation by turning
- Shower head holder suitable for various hand shower types
- single-point wall attachment with 3mm tolerance compensation (= ffl 1.5mm) for an easy and safe installation,
- concealed screw fixing
- In case of lightweight partition walls a backfill made of min. 30mm hardwood is needed
- CE-certified
- meets the requirements of German standard DIN 18040 and Austrian standard ÖNORM B 1600
- supplied with stainless steel hexagon head screws  $\varnothing 6 \times 100$  mm according to DIN 571 and dowels

