

Product data sheet

Care Solutions · Nylon Care 400

NORMBAU

PASSION FOR CARE

Nylon Care 400 Hanging seat

Article number: 4847114019

Product image



Technical specifications

Product group	2000
Product	Hanging seat
Length	510 mm
Height	505 mm
Width	570 mm
Material	polyamide
Surface	high gloss with antibacterial protection
Colour	available in colours Dark grey (018), White (019) and Manhattan (067)
Loading	max. 175 kgs

Technical drawing

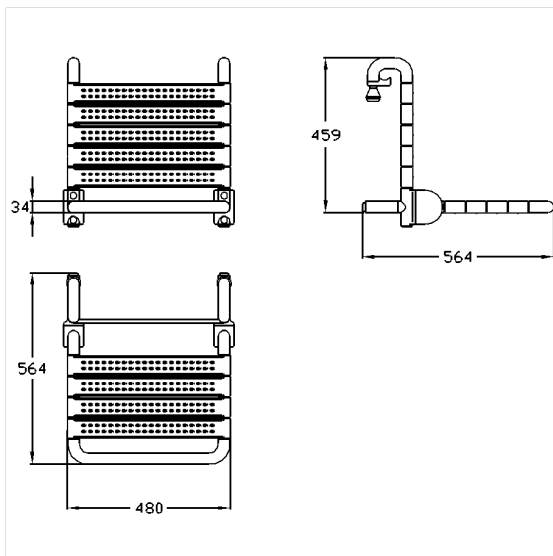

Product description

- Nylon Care - a well-trying and proven product family with a wide range of variants, three product series suiting many different requirements
- for hanging in Cavere Care Shower handrails
- for hanging in Inox Care and Nylon Care Shower handrails
- Pad with non-corrosive metal core throughout,
- with adjustable brake
- locked in place in vertical position
- with non-corrosive steel core throughout
- steel reinforced hinges
- with adjustable brake
- locked in place in vertical position
- for top edge of shower handrail 850mm the seat height corresponds 460 mm (DIN18040 und ÖNORM B1600)
- retrofittable with armrest 7843100



Antibac



018 019 067