

NORMBAU

PASSION FOR CARE

Cavere[®] Care

- DE Montage- und
Gebrauchsanleitung
- EN Fixing instruction and
directions for use
- FR Instructions de montage et
d'utilisation
- NL Montage- en
gebruiksaanwijzing



7500 410

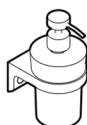

7500 461



7500 430



7500 440
7500 450



7500 420

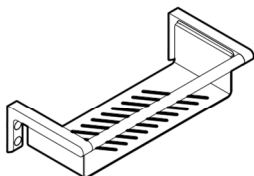

7510 350

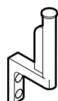

7520 120

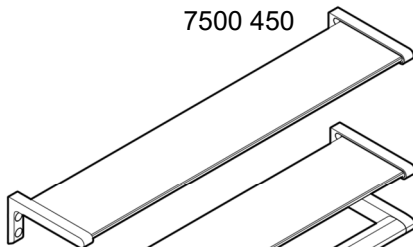

7510 160

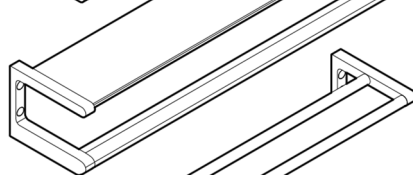

7510 260

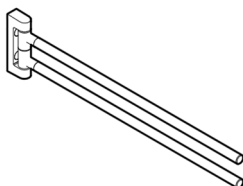

7500 582



7520 130

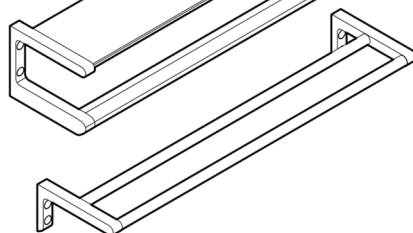

7500 310



Weitere Informationen
Further information
Plus d'informations
Meer informatie
www.shop.normbau.de

1

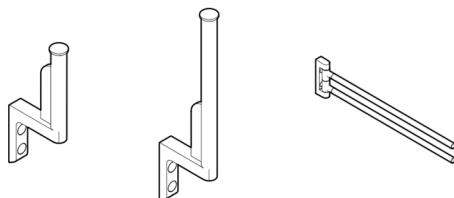
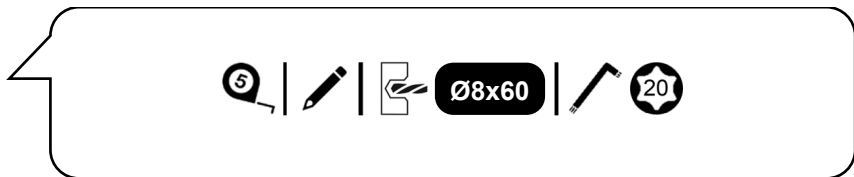

1.1

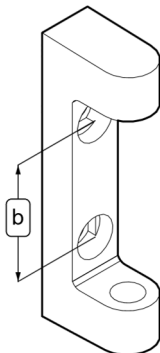

	b
7520 120	27 mm
7520 130	27 mm
7500 582	40 mm

1.2

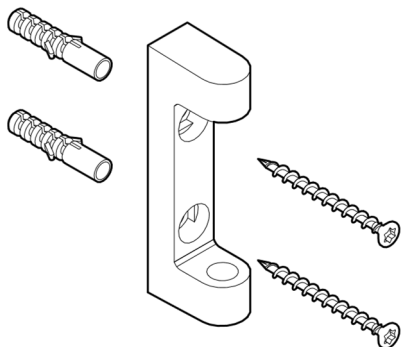

1.3

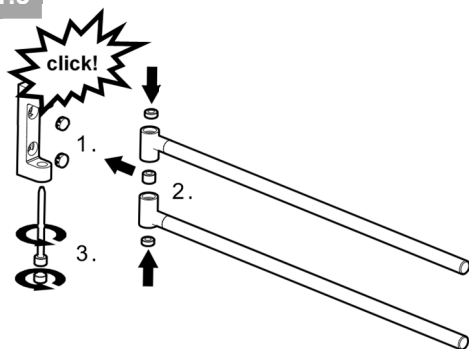

2

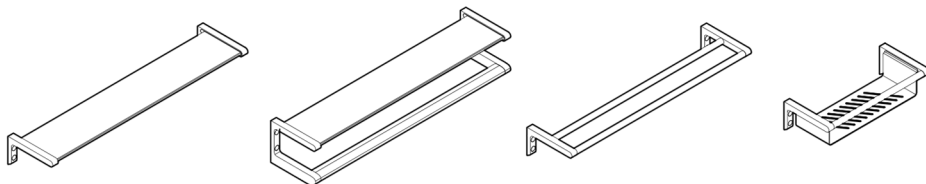

2.1

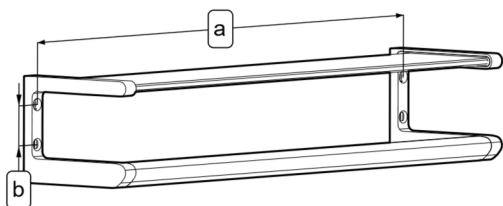

	a	b
7500 310	580 mm	27 mm
7510 160	632 mm	27 mm
7510 260	632 mm	45 mm
7510 350	320 mm	27 mm

2.2

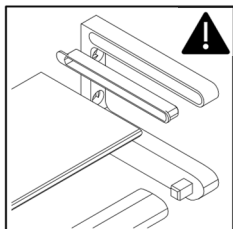

2.3



3

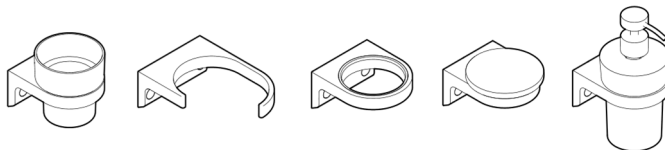
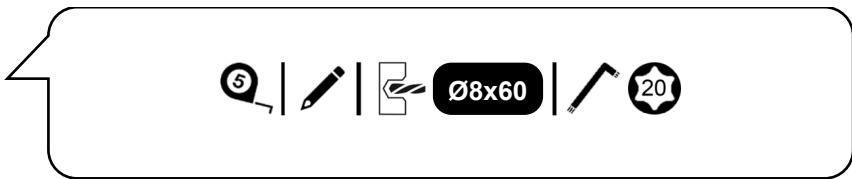

3.1



Ø8x60

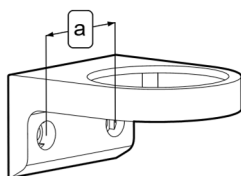

	a
7500 461	52 mm
7500 440	52 mm
7500 450	52 mm
7500 430	52 mm
7500 410	82 mm
7500 420	62 mm

3.2

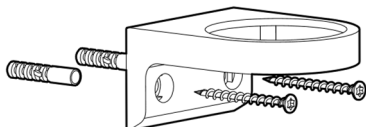

3.3

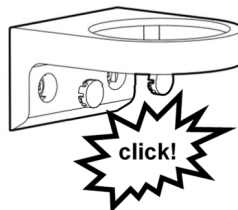

3.4

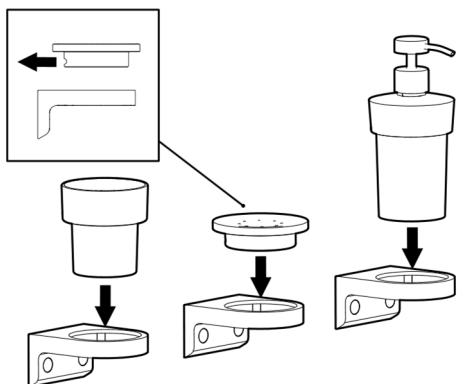

DE

Pflege- und Reinigungshinweise

Nur mit einem feuchten Tuch oder Spülmittel reinigen. Keine Chemikalien, Alkohol oder Essigreiniger verwenden.

Haftungsausschluss

Die Firma NORMBAU übernimmt keine Haftung für Personen- oder Sachschäden, die durch unsachgemäße Montage, Anwendung oder Reinigung, insbesondere unter Missachtung der in dieser Anleitung aufgeführten Warn- und Sicherheitshinweise, entstehen oder entstanden sind. Die Gewährleistung beträgt entsprechend der derzeitigen Regelung zwei Jahre.

Unter den vorgesehenen Einsatzbedingungen und unter Einhaltung der Richtlinien für Wartung und Reinigung beträgt die vorgesehene Lebensdauer des Artikels fünf Jahre.

Wünschen Sie weitere Informationen zu den Produkten, dann besuchen Sie uns unter www.normbau.de oder kontaktieren Sie uns über den Kundenservice +49 (0)7843 704 0.

Für eine vergrößerte Ansicht finden Sie diese Montageanleitung unter Eingabe der Artikelnummer auf der Homepage.

FR

Instructions d'entretien et de nettoyage

Nettoyer uniquement à l'aide d'un chiffon humide ou de liquide vaisselle. Ne pas utiliser de produits chimiques, alcool ou vinaigre blanc.

Exclusion de garantie

NORMBAU décline toute responsabilité en cas de dommages corporels ou matériels causés par un montage, une utilisation ou un nettoyage incorrect, notamment par le non-respect des avertissements et des consignes de sécurité figurant dans ses instructions. Selon la réglementation en vigueur, la période de garantie est de deux ans.

Dans les conditions d'utilisation prévues et conformément aux directives d'entretien et de nettoyage, la durée de vie prévue de l'article est de cinq ans.

Vous souhaitez des informations supplémentaires sur nos produits, visitez notre site www.normbau.de ou contactez notre service relations clients au +49 (0)7843 704 0.

Les instructions de montage peuvent également être téléchargées sur le site Web avec le code article pour une vue agrandie.

EN

Care and cleaning instructions

Only use a damp cloth or washing-up liquid to clean. Do not use any chemical, alcohol or vinegar-based cleaners.

Disclaimer of liability

NORMBAU assumes no liability for personal injury or property damage that arises or has arisen as a result of improper assembly, use or cleaning, in particular in disregard of the warning and safety instructions listed in these instructions. According to the current regulation, the warranty is two years.

Under the intended conditions of use and in compliance with the guidelines for maintenance and cleaning, the intended lifespan of the article is five years.

If you would like to get more information about the products, visit us at www.normbau.de or contact us via customer service +49 (0) 7843 704 0.

For an enlarged view, you can find these assembly instructions by entering the article number on the homepage.

NL

Onderhouds- en reinigingsinstructies

Reinig uitsluitend met vochtige doek, of afwasmiddel. Gebruik geen chemicaliën, alcohol, of schoonmaakazijn.

Disclaimer

De firma NORMBAU is niet verantwoordelijk voor persoonlijk letsel of materiele schade veroorzaakt door onjuiste montage, gebruik of reiniging. In het bijzonder als de veiligheidsaanwijzingen niet in acht zijn genomen. De garantie is volgens de standaard geldende regeling twee jaar.

Onder de beoogde gebruiksvoorwaarden en in overeenstemming met de richtlijnen voor onderhoud en reiniging, is de verwachte levensduur van het artikel vijf jaar.

Indien u meer informatie wilt over onze producten, bezoek dan onze website, www.normbau.de of neem contact op met onze klantenservice + 49 7843 704 0.

De Montage instructies kunnen ook worden gedownload van de website onder het artikelnummer voor een grotere weergave.

NORMBAU GmbH

Schwarzwaldstraße 15

77871 Renchen Germany

E-Mail: normbau@allegion.com

Internet: www.normbau.de

2023-05-23 / 8214 240 / D



ALLEGION

8 von 8 | NORMBAU