

Care Solutions · Eco Care

Eco Care Shower handrail,
with shower head rail

Article number: 1485350019

Product image



Technical specifications

Product group	3700
Product	Shower handrail, with shower head rail
Axle dimension a1	500 mm
Axle dimension a3	1200 mm
Fixing type	rosettes mounting
Fixing points	3 Piece
Diameter	32 mm
Material	Stainless steel, Shower head holder made of polyamide
Surface	scratch-resistant powder coating with antibacterial protection
Colour	White (019)
Version	left and right
Loading	max. 175 kgs

Technical drawing

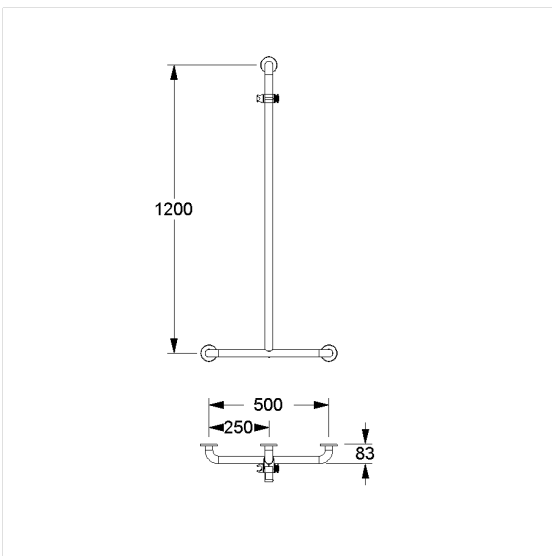

Product description

- Eco Care as solid and low-cost Care Solution
- Shower head holder with easy adjustment to any height and angle, self-adjusting clamp maintenance-free
- with long operating handle and multi-purpose side hook
- Shower head holder suitable for various hand shower types
- with plastic rose \varnothing 70mm for concealed screw fixing and glass fiber reinforced plastic base
- In case of lightweight partition walls a backfill made of min. 20mm hardwood is needed
- supplied with stainless steel Torx screw $s\varnothing$ 6 x 70 mm and plugs



Antibac



019