

Care Solutions · Nylon Care 300

Nylon Care 300 Shower head rail,
movable

Article number: 0300892016

Product image

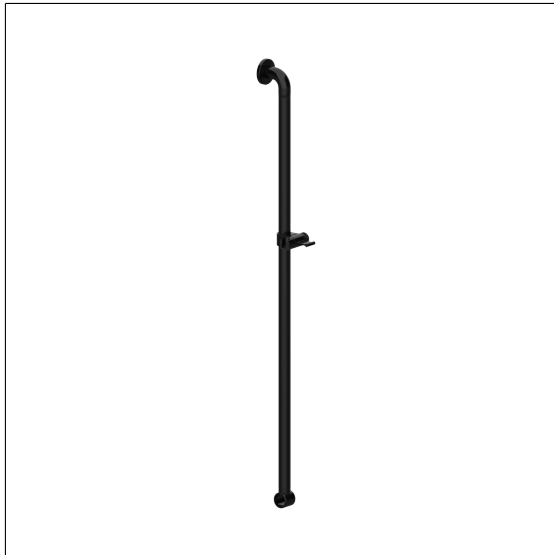

Technical specifications

Product group	0700
Product	Shower head rail, movable
Fixing type	rosettes mounting
Fixing points	1 Piece
Axle dimension a1	1158 mm
Material	polyamide
Surface	high gloss
Diameter	34 mm
Version	left and right
Colour	available in nylon colours

Technical drawing

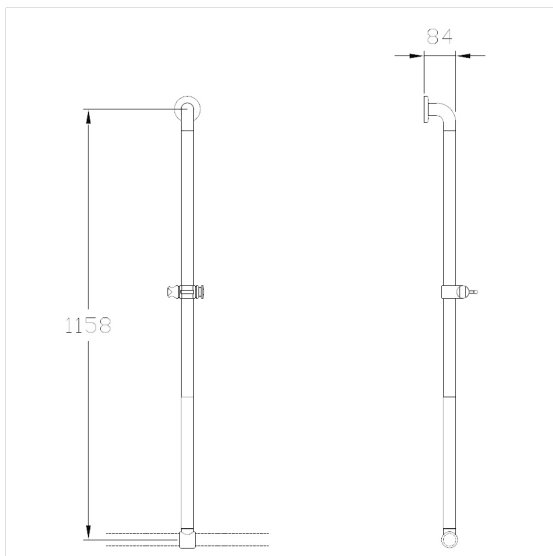

Product description

- Nylon Care - a well-trying and proven product family with a wide range of variants, three product series suiting many different requirements
- for retrofitting to Nylon Care 300 shower handrails and grab rails from a1 = 800 mm
- with non-corrosive steel core throughout
- Shower head holder with easy adjustment to any height and angle, self-adjusting clamp maintenance-free
- with long operating handle and multi-purpose side hook
- Shower head holder suitable for various hand shower types
- with Rose Gasket for sealing of the drilling points according to German standard DIN 18534-1
- with plastic rose Ø 70mm for concealed screw fixing and glass fiber reinforced plastic base
- In case of lightweight partition walls a backfill made of min. 20mm hardwood is needed
- supplied with stainless steel Torx screw sØ 6 x 70 mm and plugs

