

Care Solutions · Cavere Care

Cavere Care Shower handrail,
with movable shower handrail

Article number: 7485090091

Product image



Technical specifications

Product group	7000
Product	Shower handrail, with movable shower handrail
Axle dimension a2	900 mm
Axle dimension a3	1200 mm
Fixing type	L-support
Fixing points	3 Piece
Material	aluminium
Surface	scratch-resistant powder coating with antibacterial protection (except 091 Carbon black)
Colour	available in Cavere colours
Version	left and right
Loading	max. 150 kgs

Technical drawing

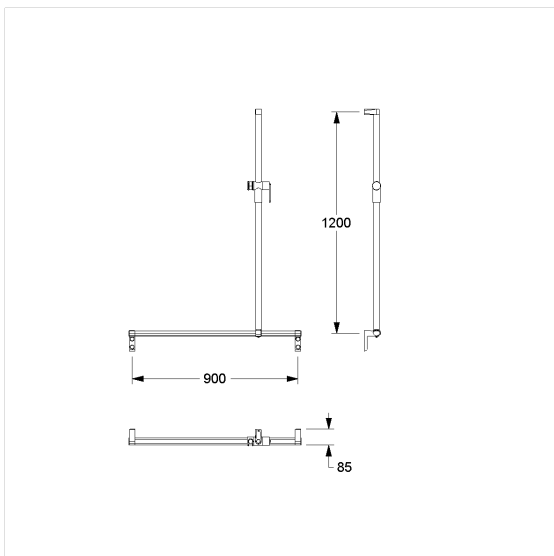

Product description

- Cavere Care as an award-winning product family with excellent design for all requirements
- ergonomic by trigonometric handle contour
- Shower head holder with easy adjustment to any height and angle, self-adjusting clamp maintenance-free
- side-mounted operating handle for one-handed operation without turning,
- Shower head holder with plastic insert, suitable for various hand shower types
- In case of lightweight partition walls a backfill made of min. 20mm hardwood is needed
- produced in accordance with Regulation (EU) 2017/745 on medical devices
- CE-certified
- meets the requirements of German standard DIN 18040 and Austrian standard ÖNORM B 1600
- supplied with stainless steel Torx screw $s\varnothing$ 6 x 70 mm and plugs

