

Care Solutions · Nylon Care 400

Nylon Care 400 Hygiene bag dispenser,
with retaining bracket

Article number: 4466010019

Product image

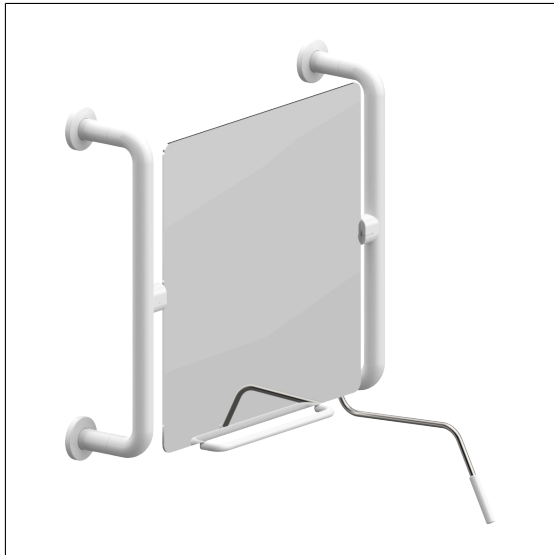

Technical specifications

Product group	2000
Product	Hygiene bag dispenser, with retaining bracket
Length	660 mm
Width	148 mm
Height	570 mm
Glass thickness	4 mm
Material	polyamide, mirror made of crystal glass
Surface	high gloss with antibacterial protection
Colour	available in colours Dark grey (018), White (019) and Manhattan (067)

Technical drawing

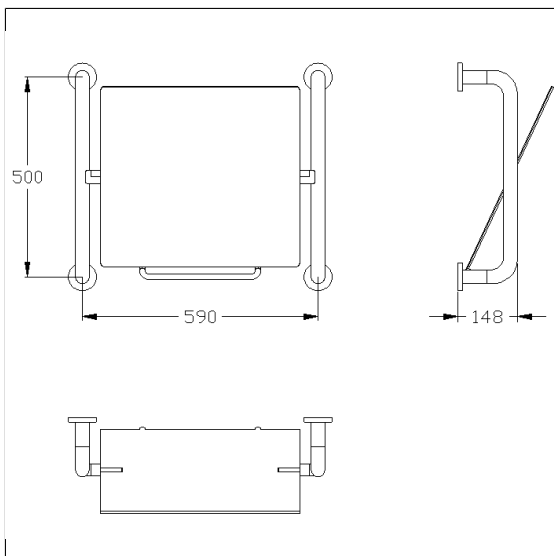

Product description

- Nylon Care - a well-tried and proven product family with a wide range of variants, three product series suiting many different requirements
- mirror 500 x 500mm with cut edges and rounded corners, mounted on steel base plate
- retrofitting with Care mirror lamp 0300669 und 0300666
- retrofitting with Care operating handle 0466450, optional with antibacterial protection 4466450
- supplied with stainless steel Torx screw sØ 6 x 70 mm and plugs



Antibac



018 019 067