

Care Solutions · Cavere Care

Cavere Care Lift-up support rail vario

Article number: 7447030095

Product image



Technical specifications

Product group	7000
Product	Lift-up support rail
System	vario, with base plate
Length	850 mm
Material	aluminium, base plate, made of stainless steel
Surface	scratch-resistant powder coating with antibacterial protection (except 091 Carbon black)
Colour	available in Cavere colours
Version	left and right
Loading	max. 100 kgs

Technical drawing

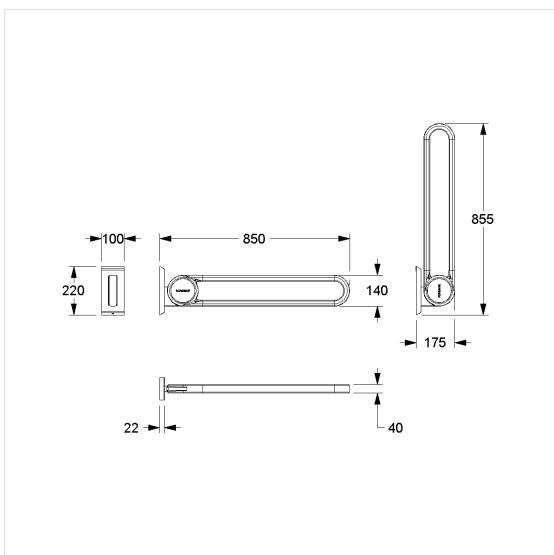

Product description

- Cavere Care as an award-winning product family with excellent design for all requirements
- ergonomic by trigonometric handle contour
- with adjustable brake
- with durable maintenance-free, friction bearings
- easy installation or removing by connecting / disconnecting to base plate
- concealed screw fixing
- In case of lightweight partition walls a backfill made of min. 20mm hardwood is needed
- certified by TÜV PRODUCT SERVICE
- produced in accordance with Regulation (EU) 2017/745 on medical devices
- CE-certified
- meets the requirements of German standard DIN 18040 and Austrian standard ÖNORM B 1600
- Fixing set has to be determined according to conditions on site, is to be ordered separately
- in combination with Care shower guard rails 0787015 / 0787056 also can be used as shower guard rail



Antibac Vario



091 092 093 095 096