

## Care Solutions · Cavere Care

Cavere Care Shower handrail,  
with movable shower handrail

Article number: 7485061095

### Product image



### Technical specifications

Product group	7000
Product	Shower handrail, with movable shower handrail
Axle dimension a2	600 mm
Axle dimension a3	1200 mm
Fixing type	single-point mounting
Fixing points	3 Piece
Material	aluminium
Surface	scratch-resistant powder coating with antibacterial protection (except 091 Carbon black)
Colour	available in Cavere colours
Version	left and right
Loading	max. 150 kgs

### Technical drawing

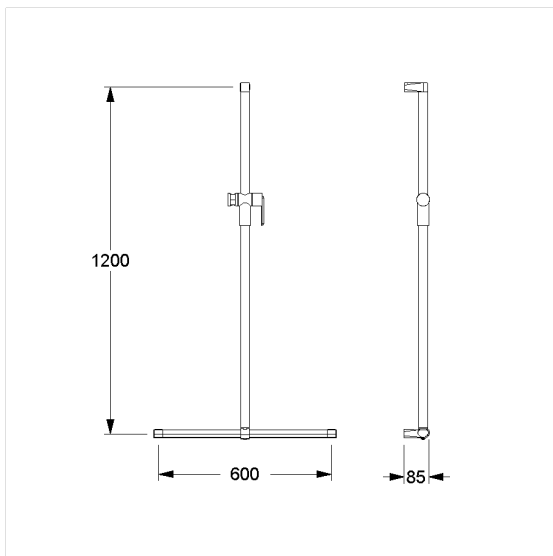

### Product description

- Cavere Care as an award-winning product family with excellent design for all requirements
- ergonomic by trigonometric handle contour
- Shower head holder with easy adjustment to any height and angle, self-adjusting clamp maintenance-free
- side-mounted operating lever for one-handed operation without turning,
- Shower head holder with plastic insert, suitable for various hand shower types
- single-point wall attachment with 3mm tolerance compensation (= ffl 1.5mm) for an easy and safe installation,
- concealed screw fixing
- In case of lightweight partition walls a backfill made of min. 30mm hardwood is needed
- CE-certified
- meets the requirements of German standard DIN 18040 and Austrian standard ÖNORM B 1600
- supplied with stainless steel hexagon head screws  $\varnothing 6 \times 100$  mm according to DIN 571 and dowels



Antibac



091 092 093 095 096