

Care Solutions · Cavere Care

Cavere Care Lift-up support rail,
for side fixing

Article number: 7447214095

Product image



Technical specifications

Product group	7000
Product	Lift-up support rail, for side fixing
Length	600 mm
Material	aluminium
Surface	scratch-resistant powder coating with antibacterial protection (except 091 Carbon black)
Colour	available in Cavere colours
Version	right
Loading	max. 100 kgs

Technical drawing

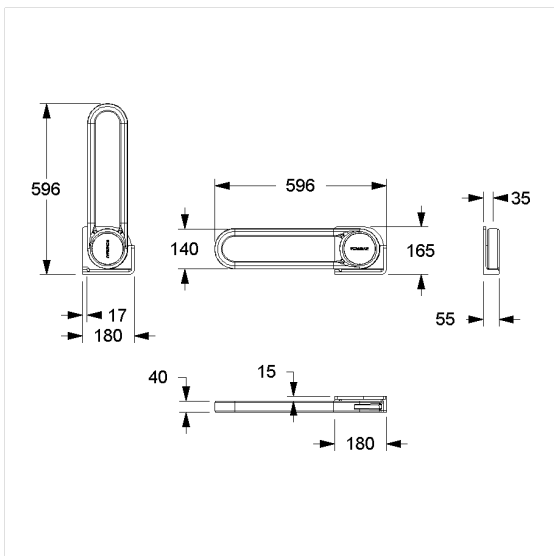

Product description

- Cavere Care as an award-winning product family with excellent design for all requirements
- ergonomic by trigonometric handle contour
- with adjustable brake
- with durable maintenance-free, friction bearings
- In case of lightweight partition walls a backfill made of min. 20mm hardwood is needed
- produced in accordance with Regulation (EU) 2017/745 on medical devices
- CE-certified
- meets the requirements of German standard DIN 18040 and Austrian standard ÖNORM B 1600



Antibac

